

Rocla's reliable Solid pedestrian stackers increase the productivity and flow of work thanks to their versatility. Compact and agile stackers are excellent for fast and safe lifting and lowering of pallets also in tight spaces. Easy to operate pedestrian stackers are designed for demanding material handling in retail and whole sale and industrial warehouses.

## Rocla

*The intelligent way to move*

## Stackers

SWS10/12(i)/14(i)/16(i)/16s



### SOLID

- Robust construction with recyclable parts makes stackers both durable and sustainable.
- High lifting and lowering speed and competitive residual capacities increase productivity of working.
- Stepless lifting and lowering in all models ensures fast working.
- Completely closed chassis and moisture resistant electrics ensure protection against dirt, dust and moisture for extended lifecycle and low maintenance need.
- Versatile battery compartment accommodates standard size batteries with a variety of capacities.
- Extended product line offers several mast options in four lifting capacities as well as initial lift and straddle models.







SWS12i/14i/16i

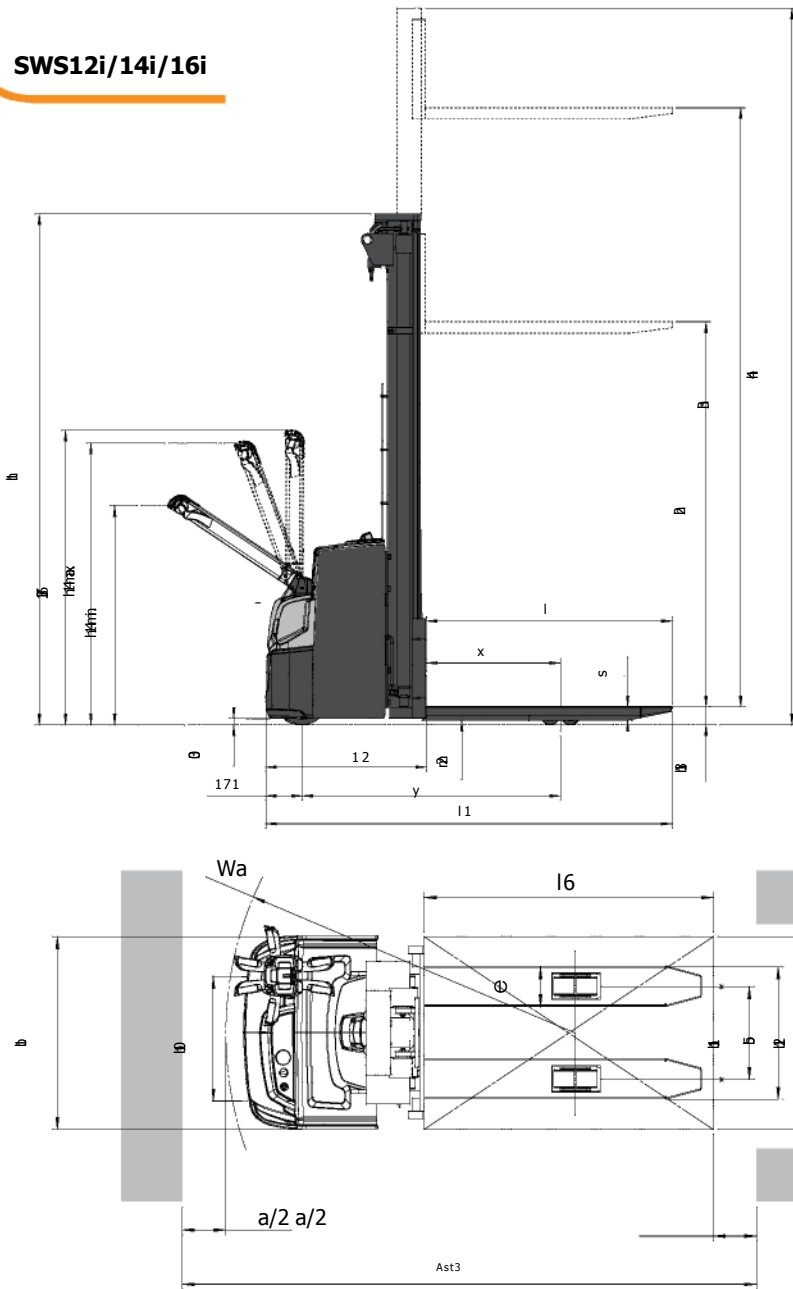

SWS12i SWS14i SWS16				
ftng mast	h3+h13	h1	h4	h2+h13
<b>S</b>	1500	2055	2055	1505
<b>DS</b>	2500	1940	3105	200
	2900	2140	3505	200
	3300	2340	3905	200
	3600	2490	4205	200
	4300	2840	4905	200
<b>DEV</b>	2500	1940	3105	1360
	2900	2140	3505	1560
	3300	2340	3905	1760
	3600	2490	4205	1910
	4300	2840	4905	2260
<b>TR</b>	4100	2060	4745	-
	4300	2125	4945	-
	4700	2153	5345	-
	5400*	2490	6045	-
<b>TREV</b>	4100	2060	4745	1480
	4300	2125	4945	1545
	4700	2153	5345	1673
	5400*	2490	6045	1910

S = Simplex  
 DS = Duplex with clear view mast  
 DEV = Duplex with full free lift  
 TR = Triplex with clear view mast  
 TREV = Triplex with full free lift  
 h3+h13 = Lifting height  
 h1 = Lowered mast height  
 h4 = Raised mast height  
 h2+h13 = Free lift



SWS16s

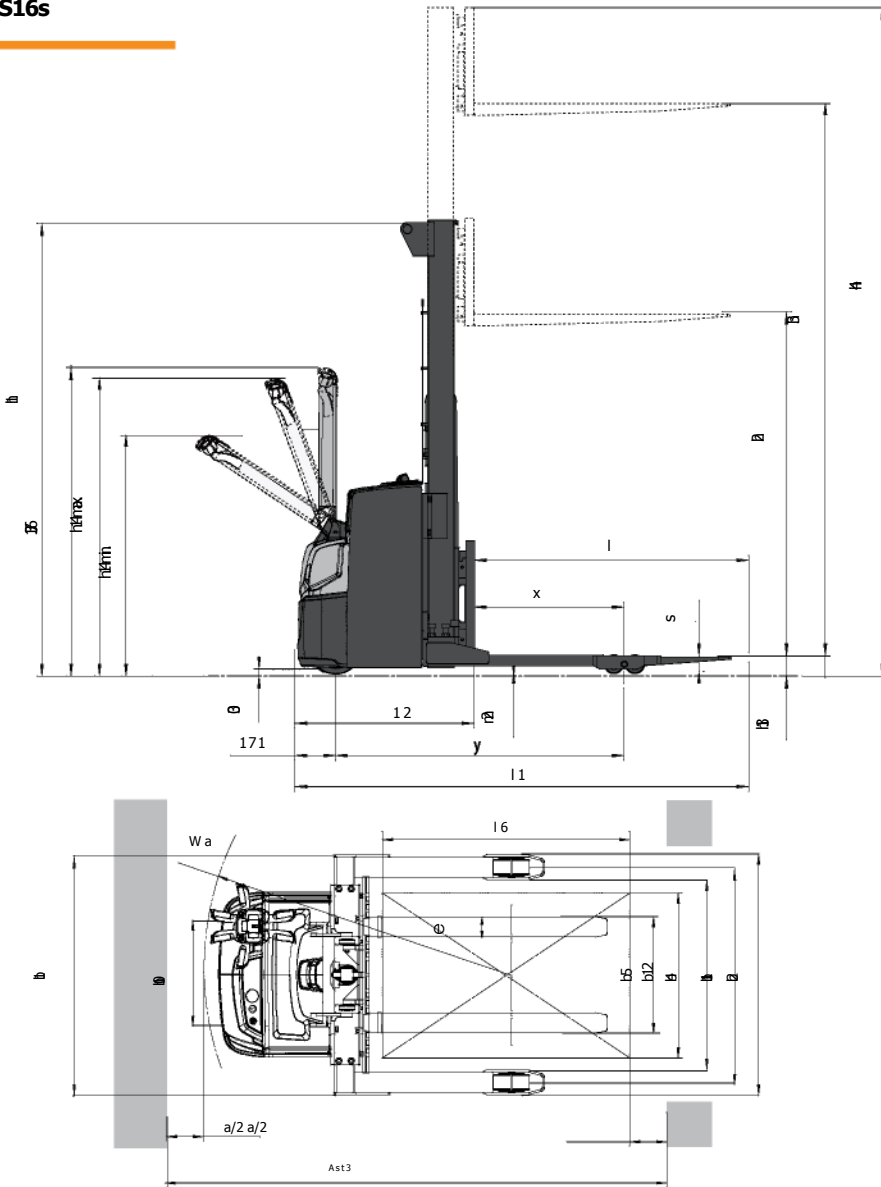

SWS16S					
ftig mast	h3h3	h1	h4	h2h13	
S	1500	1950	1950	1500	
DS	2500	1835	3000	200	
	2900	2035	3400	200	
	3300	2235	3800	200	
	3600	2385	4100	200	
	4300	2735	4800	200	
DEV	2500	1775	2940	1355	
	2900	1975	3340	1555	
	3300	2235	3800	1755	
	3600	2385	4100	1905	
	4300	2735	4800	2255	
TR4100		1955	4640	-	
		4300	2020	4840	-
		4700	2153	5240	-
		5400	2385	5940	-
TREV4100		1955	4640	1475	
		4300	2020	4840	1540
		4700	2153	5240	1673
		5400	2385	5940	1905

# SWS10/12(i)/14(i)/16(i)/16s

Designed for versatile use, Solid stackers with maximum lifting height of 5400 mm, have extremely strong, endurance-tested and well-protected construction, less breakable components, low energy consumption and recyclable parts. Low center of gravity ensures excellent stability. Large lifting and lowering levers for ergonomic h2 tiller arm allow easy, one-handed control. Operator can adjust the speed, acceleration and braking according to the application and user preferences with two operating modes, soft and performance. Soft mode makes using the machine easy also for inexperienced drivers while saving energy.



1. Off-set tiller and the advanced construction of the stacker ensure the operator has excellent visibility to fork tips also in high liftings up to 5400 mm.



1. Narrow chassis and small turning circle make loading/unloading easy also in confined areas. Stepless lifting and lowering of the mast enables faster working.



1. Initial lift models are perfect on steep ramps and uneven floors. The strong, endurance-tested forks construction ensures smooth pallet handling even with the heaviest loads.

## Options

- Design covers
- PIN code unit
- Load backrest
- Accessory rack
- List bracket, A4 size
- Computer rack
- Bottleholder
- Penholder
- Current output
- In-built charger
- Cold store modification
- Multifunctional Display, including Hourmeter
- Speed reduction 0,5 km/h above 1000 mm lift, DS and TR
- Speed reduction 0,5 km/h above free lift, DEV and TREV

\*not available for SWS10



*The intelligent way to move*

**IHS, S. A. de C. V.**

Bldv. Adolfo López Mateos # 201  
Int. 39-41. Col. Santa Cruz Acatlán

C. P. 53150, Naucalpan

Estado de México

México

Tel. 55-53606323 /10 líneas

[www.ihscompany.com](http://www.ihscompany.com)

[ihs@ihscompany.com](mailto:ihs@ihscompany.com)